



Portable Power

BALLOON LIGHT BL400, BL600 OPERATION & MAINTENANCE MANUAL

Original Instruction



This manual contains important safety information and must be made available to personnel who operate and maintain this machine.

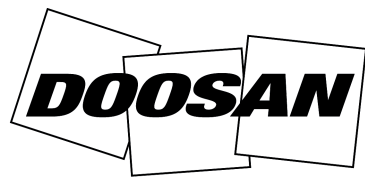

Portable Power

ACKNOWLEDGEMENTS

You have just acquired a balloon. Thank you for choosing DOOSAN. We hope this product gives you total satisfaction.

Please feel free to send your remarks to our Customer Service department.

LET THERE BE LIGHT

The BALLOON LIGHT is specifically designed for night work: rescue, safety, work-site operations, etc.

EXTREMELY IMPORTANT SAFETY INSTRUCTIONS

Ensure that the operator reads and *understands* the decals and consults the manuals before maintenance or operation.



REDUCE THE RISK OF FIRE, ELECTRIC SHOCK, EXPOSURE TO EXCESSIVE UV RADIATION, OR INJURY:

1. LIGHTED LEDs ARE EXTREMELY HOT. Turn off, unplug, and allow the unit to cool before touching LEDs.
2. ALWAYS disconnect your equipment before servicing.
3. Do not touch the lamp cage until it has completely cooled.
4. Do not look directly at lighted lamps.
5. Do not operate the Balloon Light unit near flammable materials.
6. Use only with LED light engine 46769985 (BL400 - 6000°K) or 46700835 (BL600 - 6000°K).
7. Use a soft cloth or glove when handling lamps. Oil from skin may damage the lamp during operation.
8. Do not operate the Balloon Light with damaged electronics or if parts are missing.
9. Do not operate the Balloon Light with a damaged envelope or without an envelope.
10. All service must be performed by DOOSAN qualified personnel only. See Warranty Info for details.
11. Always use this lighting equipment at heights of at least 5ft (1,5m).

12. Do not operate your stand-mounted Balloon Light on an uneven surface or a gradient of more than 8 degrees.
13. Do not use the Envelope if the wind speed exceeds 50mph (80km/h).
14. Use only recommended stands with an ability to support a 20lb (9kg) Balloon Light unit, and endure wind speeds of 50mph (80km/h) at a height of 16,5ft (5m).



When using outdoors, basic safety precautions should always be followed to reduce the risk of fire, electric shock, and personal injury, including the following:

1. Use only NEMA 5-15 "Edison" plug extension cords connected to the correct electrical source outlets.
2. Always use Ground Fault Circuit Interrupter (GFCI) protection when operating your Balloon Light in areas near water, and during inclement weather.

KEEP THESE INSTRUCTIONS WITH YOUR PRODUCT

MINIMUM DISTANCES NEAR HIGH-VOLTAGE LINES

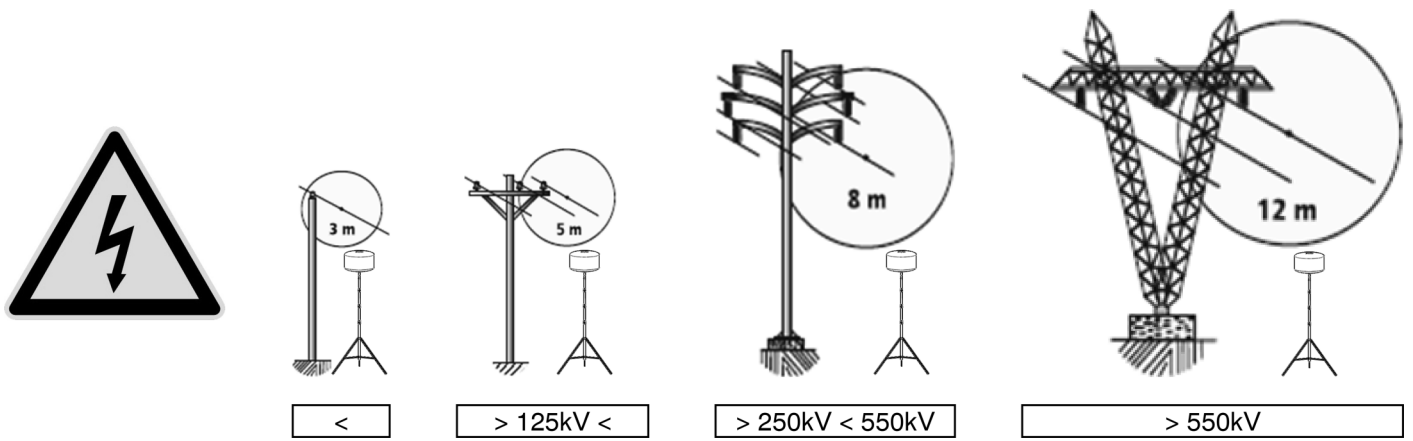

KEEP THESE INSTRUCTIONS WITH YOUR PRODUCT

PRECAUTIONARY PRINCIPLES TO RESPECT TO MAINTAIN YOUR PRODUCT WARRANTY

1. Use the included glove when handling lamps to prevent potential damage caused by the transfer of oils and dirt to glass.
2. Always disconnect the power before performing a service.
3. Do not operate your Balloon Light without its envelope, or with a damaged envelope.
4. Protect the envelope by operating away from walls, projectiles, electric wires, trees, animals, etc.
5. DO NOT LEAVE A DEFLATED ENVELOPE UNCOVERED WHEN NOT IN USE.
6. Always use the included protective cover when storing your Balloon Light. Failure to do so may result in loss of warranty coverage.
7. Store your Balloon Light in a dry, ventilated area away from heat sources and chemical products.
8. Be sure that envelope is completely dry before installing the protective cover.
9. Do not use chemical solvents to clean the envelope. Use mild soap and water as necessary.
10. Do not modify the electrical components or unit structure.
11. Do not operate your Balloon Light if the cable is damaged, twisted, or tangled.
12. Care must be taken to always operate the product with a filter as clean as possible and not clogged. The change in color or in appearance of the filter indicates that it requires cleaning. A poor air intake results in the overheating of the product that may cause a life term reduction of certain components or their destruction.
13. Care must be taken when handling the product stored in its original packaging (incorporating its reinforcements). Be careful not to drop the product under its own weight when loading or unloading. A damaged or eviscerated container will not protect the product correctly anymore and must be replaced.

FAILURE TO COMPLY WITH ONE OR MORE OF THESE RECOMMENDATIONS WILL LEAD TO LOSS OF THE PRODUCT WARRANTY.

RECOMMENDED GENERATOR CAPACITY FOR DOOSAN UNITS

14. **NOTE:** When using generator power, ALWAYS start your generator BEFORE plugging in your DOOSAN unit.
15. Generator set: minimum recommended capacity: Single phase 100-240V 50-60Hz – 1kVA.
16. **WARNING:** Be sure to avoid phase imbalance when several devices are connected to the same generator.

BUILT-IN SAFETY SYSTEMS

Your Balloon Light is equipped with special safety mechanisms that are designed to protect you and the unit in the event of equipment failure or in certain unsafe operating conditions:

- The BL600 is equipped with a safety pressure switch that turns off the light if internal envelope air pressure falls below safe operating levels.
- If a light starts blinking due to excessive heat, check and clean the filter, be sure the fan is running and that fresh air can come in. Make sure the envelope is always under surveillance.

BALLOON DESCRIPTION

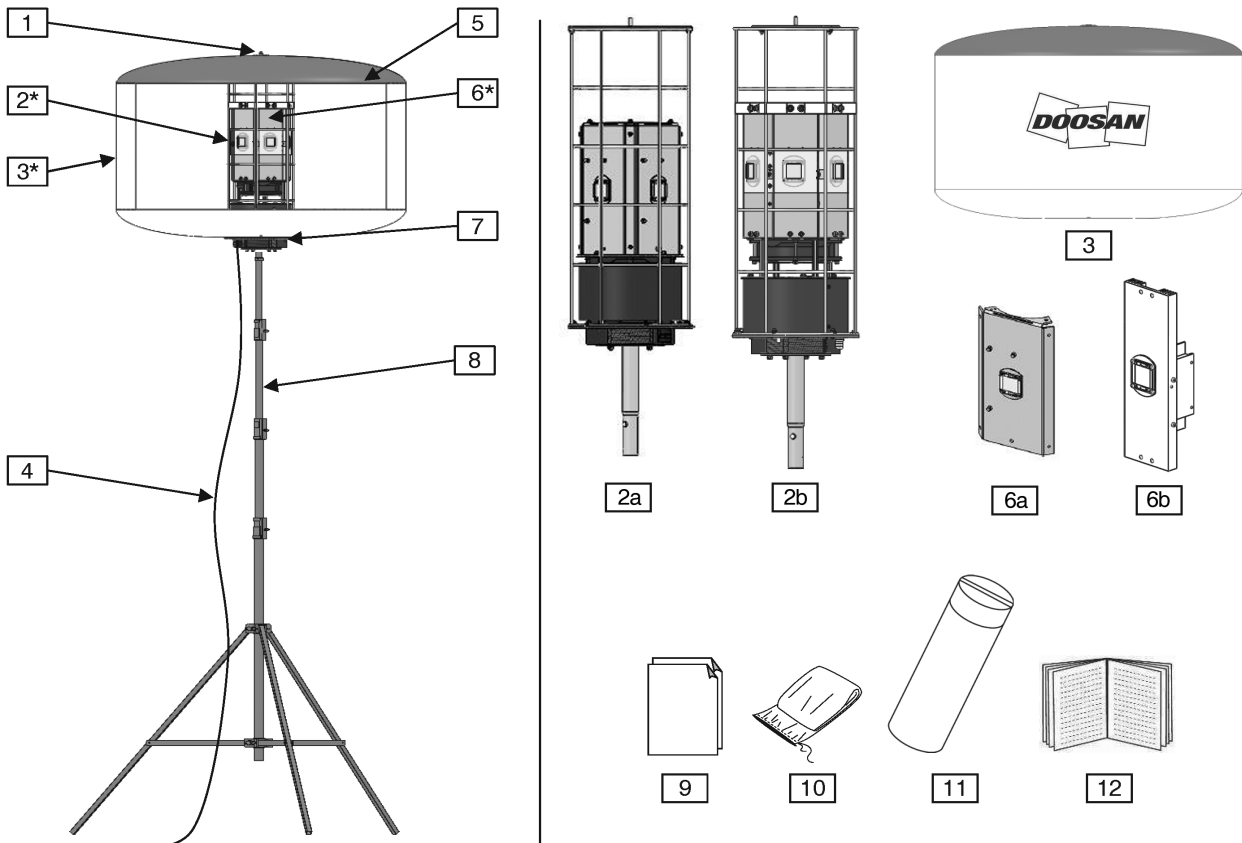

*See detail on the right

1	Nut
2a	BL400 Internal Structure (cage + base + support stem)
2b	BL600 Internal Structure (cage + base + support stem)
3	Envelope
4	Power Supply Cord
5	Zipper
6a	BL400 LED light engine (6000°K)
6b	BL600 LED light engine (6000°K)
7	South Pole Plate
8	Stand (recommended accessory purchased separately)
9	Repair Kit (2 pieces)
10	Protective Storage Cover
11	Storage Tube
12	User Manual

Remark: The stand is optional.

ENVELOPE INSTALLATION INSTRUCTIONS

Unpack your new envelope.

- Unfold the envelope on a smooth, clean surface.
- Open the zipper.

When REPLACING an old envelope, FIRST remove original envelope.

- Unplug the balloon unit and open the envelope zipper.

Figure 1



- Unscrew the nut on the top of the envelope. (Fig. 1) Set the nut safely aside.
- Pass the cage through the envelope zipper opening.

Figure 2

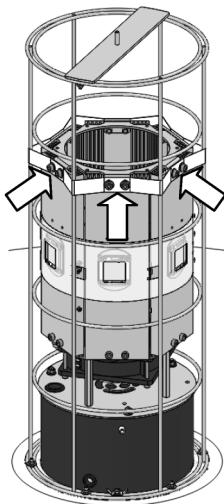

- Unscrew the 12 screws which secure the strap. (Fig. 2)

Figure 3



- Set the strap with its screws mounted aside. (Fig. 3)

Figure 4

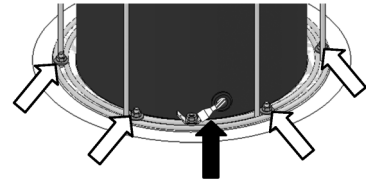

- Unplug the ground wire from the cage. (Fig. 4 black arrow)
- Unscrew the six nuts on the South Pole Plate inside the envelope. (Fig. 4 white arrows)
- Carefully remove the cage from the assembly.
- Detach the old envelope from the assembly by sliding up along the equipment.
- Put the envelope back in place.

Figure 5

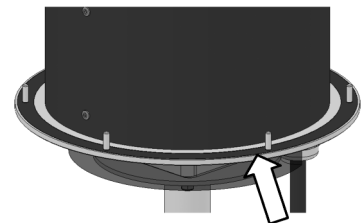

- Take care of the gasket: DO NOT lose it. (Fig. 5)
- Position the zip in front of the ground wire.
- Slide the cage inside the envelope through the zipper opening.

Figure 6

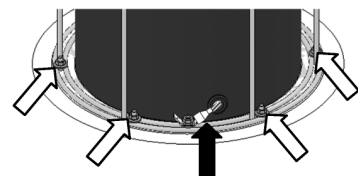

- Reattach the ground wire to the ground pin on the cage. (Fig. 6 black arrow)
- Screw the six South Pole Plate nuts onto the cage. (Fig. 6 white arrows)

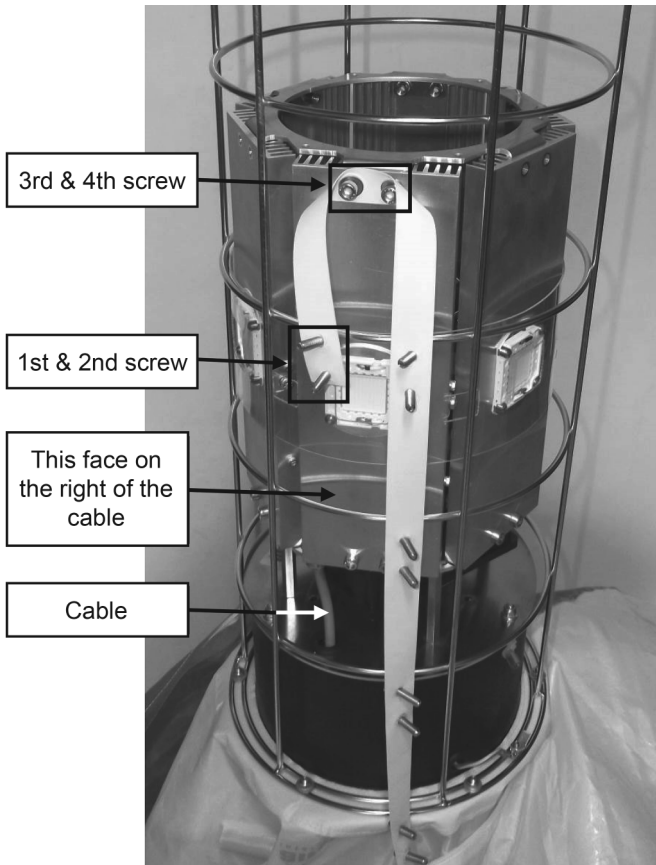

- Engage the « 3rd screw » and « 4th screw » of the strap inside the holes of the heatsink located on the right of the inside harness cable.
- Tighten these two screws for two turns only.

In order not to damage the screws, use a 4mm Allen key.

- Move the strap to the right and outside the vertical grid wire.

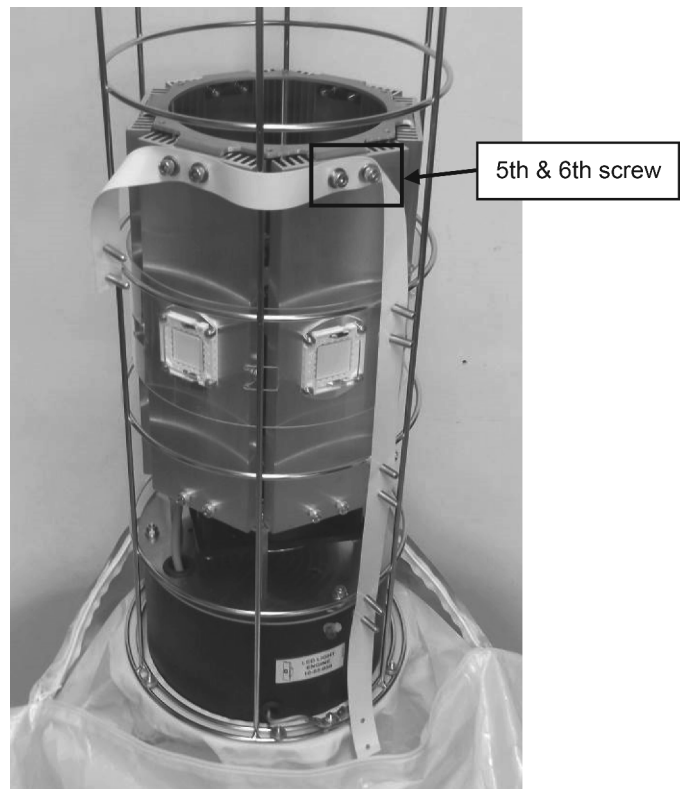

- Engage the « 5th screw » and the « 6th screw » of the strap inside the holes of the heatsink.
- Tighten these two screws for two turns only.
- Proceed around the unit in the same way with the other screws located on the strap.

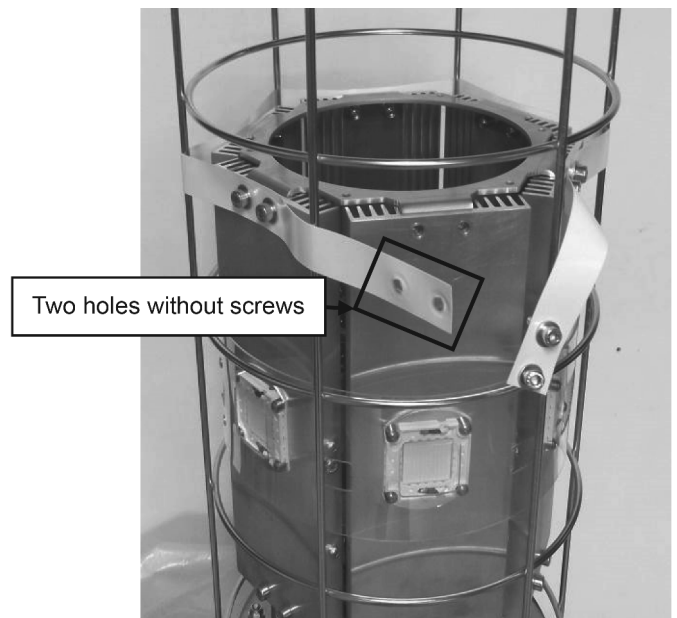

- Stop before the two last holes of the strap that do not have screws.

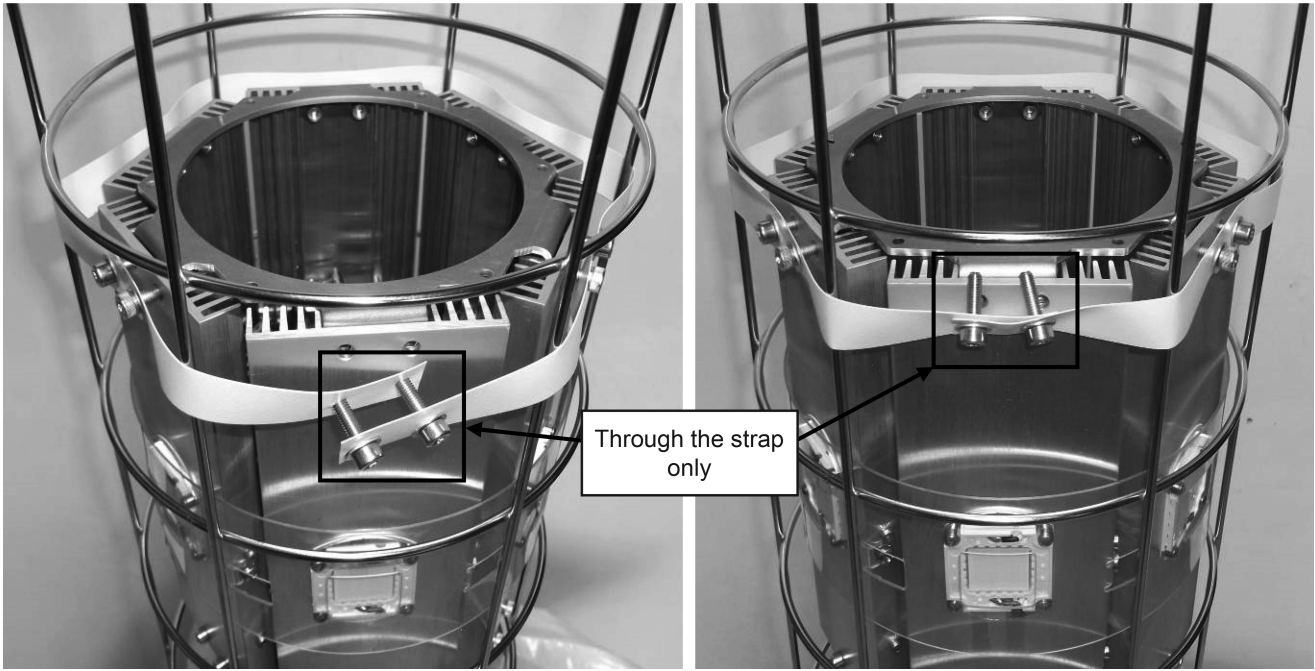

- Position the two end screws through the vacant holes at the other end of the strap and tighten these two screws for two turns only.
- Then, screw these two screws fully through both sets of strap holes only, by using a hexagonal screwdriver 4x50mm bit on a cordless screwdriver.



Model of cordless screwdriver to use: type BOSCH GSR 10.8-2-LI with hexagonal screwdriver 4x50mm bit.



- Place the two screws inside the holes of the heatsink without screwing them.
- Tighten these two screws for two turns only.

In order not to damage the screws, use a 4mm Allen key.



- Tighten the 12 screws using the cordless screwdriver set to « torque 15 » (= about 4 Nm).

If you do not have this type of screwdriver, adjust the torque setting of the available tool to 4 Nm.

Too high a torque setting may result in a twisted strap.

Too low a torque setting may result in the strap being too loose.

Figure 7



- Loosely replace the nut on the top of the envelope. Do not tighten until after the envelope is fully inflated. (Fig. 7)
- Close the zipper.
- Inflate the envelope.
- Tighten the nut on the top of the envelope. (Fig. 7)

LED LIGHT ENGINE REPLACEMENT INSTRUCTIONS

- Unplug the balloon unit and open the envelope zipper.

Figure 4

Figure 1

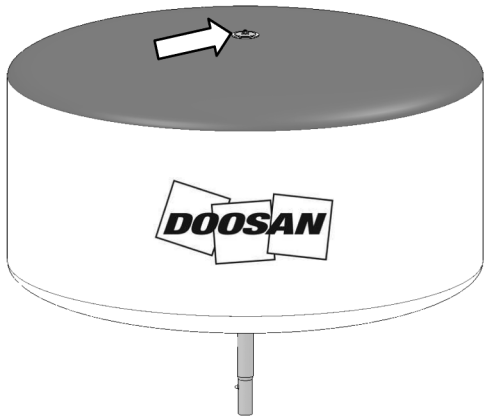

- Unscrew the nut on the top of the envelope. (Fig. 1) Set the nut safely aside.
- Pass the cage through the envelope zipper opening.

Figure 2

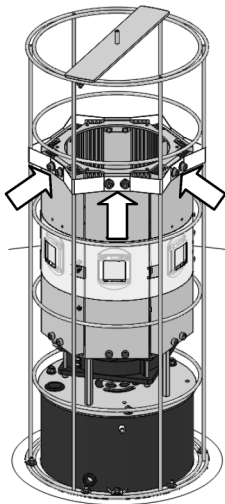

- Unscrew the 12 screws which secure the strap. (Fig. 2)

Figure 3



- Set the strap with its screws mounted aside. (Fig. 3)

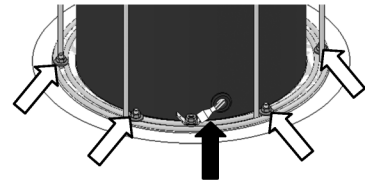

- Unplug the ground wire from the cage. (Fig. 4 black arrow)
- Unscrew the six nuts on the South Pole Plate inside the envelope. (Fig. 4 white arrows)
- Carefully remove the cage from the assembly.

Figure 5

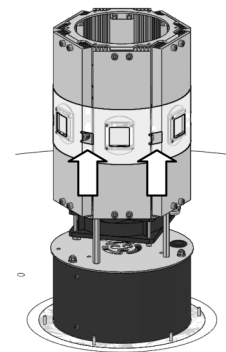

- Unscrew the six screws on the transparent cover. (Fig. 5)

Figure 6

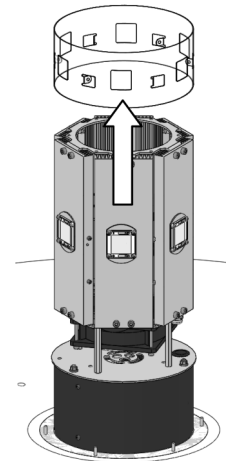

- Slide the transparent cover to the top. (Fig. 6)

Figure 7

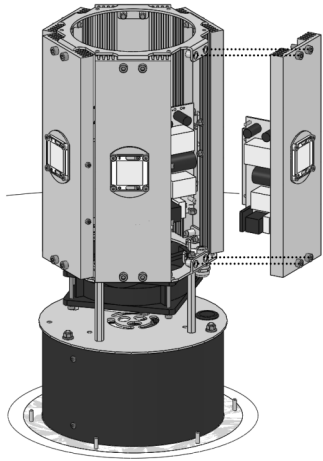

- Replace the LED light engine 10-85-058 (6000°K) with a new one. (Fig. 7)

Figure 8

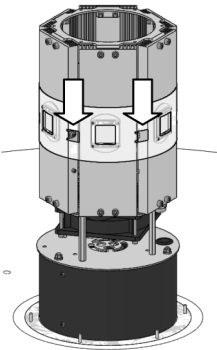

- Replace the transparent cover and screw the six screws on the transparent cover. (Fig. 8)
- Slide the cage inside the envelope through the zipper opening.

Figure 9

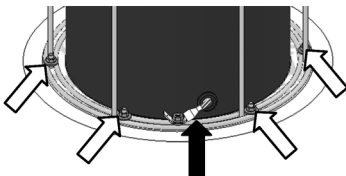

- Reattach the ground wire to the ground pin on the cage. (Fig. 9 black arrow)
- Screw the six South Pole Plate nuts onto the cage. (Fig. 9 white arrows)

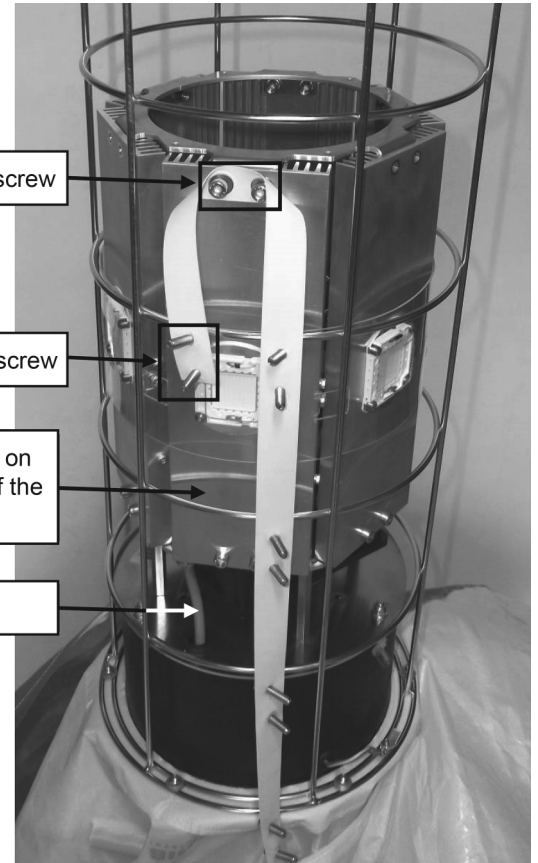

- Engage the « 3rd screw » and « 4th screw » of the strap inside the holes of the heatsink located on the right of the inside harness cable.
- Tighten these two screws for two turns only.

In order not to damage the screw, use a 4mm Allen key.

- Move the strap to the right and outside the vertical grid wire.

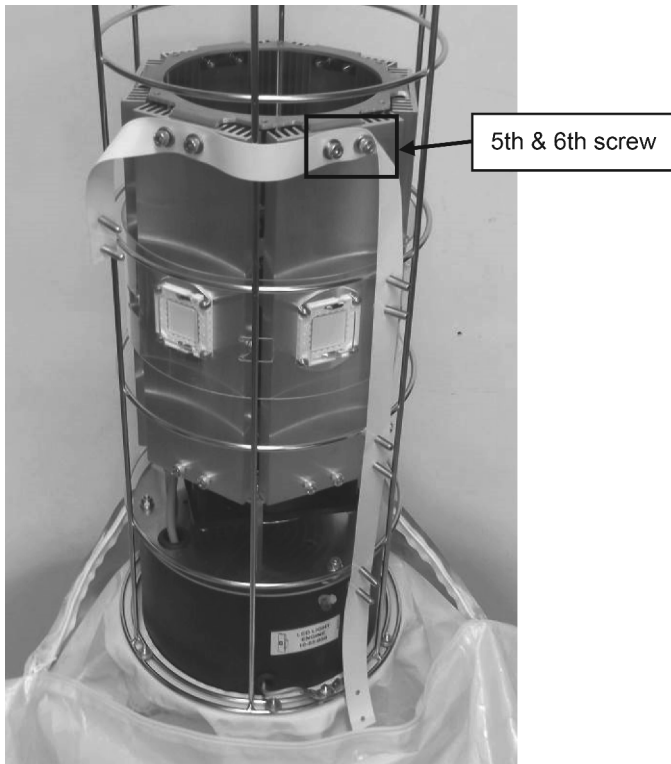

- Engage the « 5th screw » and the « 6th screw » of the strap inside the holes of the heatsink.
- Tighten these two screws for two turns only.
- Proceed around the unit in the same way with the other screws located on the strap.



- Stop before the two last holes of the strap that do not have screws.

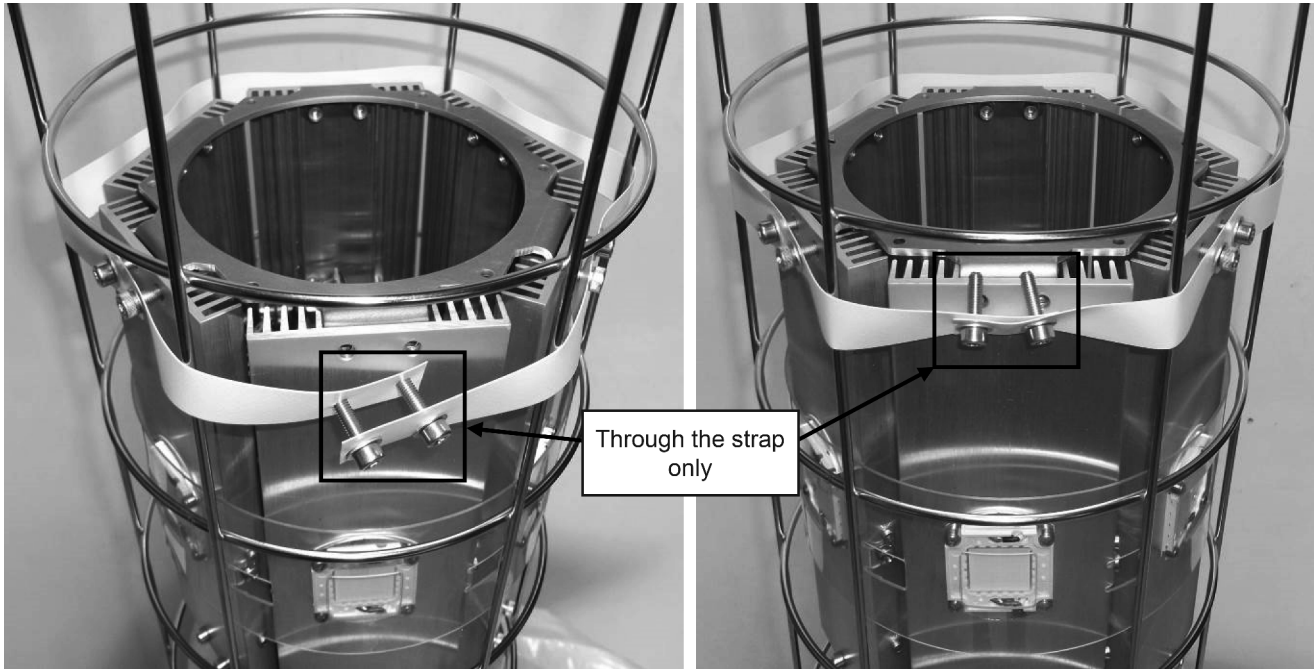

- Position the two end screws through the vacant holes at the other end of the strap and tighten these two screws for two turns only.
- Then, screw these two screws fully through both sets of strap holes only, by using a hexagonal screwdriver 4x50mm bit on a cordless screwdriver.



Model of cordless screwdriver to use: type BOSCH GSR 10.8-2-LI with hexagonal screwdriver 4x50mm bit.



- Place the two screws inside the holes of the heatsink without screwing them.
- Tighten these two screws for two turns only.

In order not to damage the screws, use a 4mm Allen key.



Figure 10



- Loosely replace the nut on the top of the envelope. Do not tighten until after the envelope is fully inflated. (Fig. 10)
- Close the zipper.
- Inflate the envelope.
- Tighten the nut on the top of the envelope. (Fig. 10)

- Tighten the 12 screws using the cordless screwdriver set to « torque 15 » (= about 4 Nm).

If you do not have this type of screwdriver, adjust the torque setting of the available tool to 4 Nm.

Too high a torque setting may result in a twisted strap.

Too low a torque setting may result in the strap being too loose.

IN THE EVENT OF BROKEN LAMP(S)

If a lamp breaks or cracks inside the envelope, disconnect the electrical power supply and disassemble the envelope. (see Envelope Installation Instructions) Be sure to remove all fragments of glass, using a vacuum cleaner to thoroughly clean the electronics and envelope. Use extreme caution when handling glass fragments to avoid injury.

INSTALLING YOUR BALLOON LIGHT ON A STAND



Always use DOOSAN approved stands designed to work with your DOOSAN unit.

Always securely tighten all T-Handles to avoid injury.

Stands are designed for vertical mounting of DOOSAN units ONLY.

USING THE OPTIONAL DOOSAN P500TA (FIG. 1) STAND.

- Unfold the stand.
- Lock the base in place.

On the P500TA, slide the stand legs out from the folded position until the support bars are exactly horizontal.

- When using your stands in windy conditions, use the following weighting recommendations to keep your stand stable.
- On the P500TA (Fig. 1), weights must be placed on each support at 20 in (50 cm) from the centre of the stand.

Follow this correlation table.

WIND SPEED	RECOMMENDATION
0 to 31 mph (0 to 50 km/h)	79 lbs (3x26.5 lbs) 36 kg (3x12 kg)
31 to 43 mph (50 to 70 km/h)	159 lbs (6x26.5 lbs) 72 kg (6x12 kg) OR guy ropes
43 to 62 mph (70 to 100 km/h)	159 lbs (6x26.5 lbs) 72 kg (6x12 kg) AND guy ropes

- Indicative for a flat floor and a steady wind, only the guy ropes ensure the mechanical strength of the feet in a strong or gusty wind.
- Guy ropes are recommended if installing on an inclined floor.
- Do not operate your stand-mounted Balloon Light on an uneven surface or a gradient of more than 8 degrees.

Figure 1

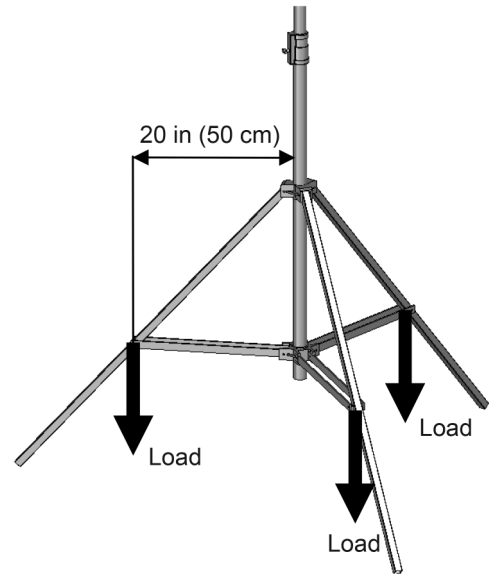

MAINTENANCE

LAMP

A damaged envelope must immediately be repaired or replaced.

Regularly clean the envelope with mild soap and water. Citrus-based cleaners can be used, although be sure to test a small area before cleaning the entire envelope.

ENVELOPE

WARNING

It is important to replace lamps showing signs of wear and tear (cracked lamp, small fragments of glass inside the lamp, or whitened lamp glass). Failure to do so could cause lamp failure, or possibly explosion, resulting in bodily injury and/or damage to the DOOSAN unit.

To replace a lamp, please refer to “Assembly (Lamp replacement)”

Patching A Hole

- Be sure to thoroughly clean the area to be patched.
- Cut a square out of the included self-adhesive fabric sheet just large enough to cover the damaged part of the envelope.
- Remove the protective film from the adhesive side of the patch material.
- Carefully place the patch onto the damaged part of the envelope, firmly applying pressure to the areas of contact around the patch edge.

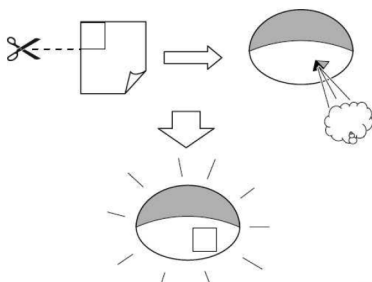

CLEANING THE AIR FILTER

Remove sponge-type air filter, located under the south pole plate, by sliding along the support stand.

Wash it or replace it.

Replace the clean air filter in the same way.

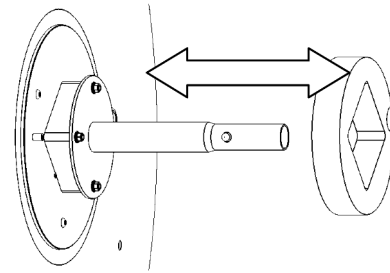

WARRANTY

The envelope of the balloon is guaranteed for 6 months from the date of purchase against any manufacturing defects and under normal conditions of use.

The rest, except for “consumables”, such as bulbs, etc., is guaranteed for 2 years from the date of purchase against any manufacturing defects and under normal conditions of use.

In any case of a manufacturing defect or incorrect operation, please return the balloon to your DOOSAN distributor.

DOOSAN cannot be held responsible for improper handling by the user. Any operation on the envelope or electric equipment that is not specified in this manual, or any use of unapproved tools, components or bulbs is not covered by this warranty and remains the sole responsibility of the user.

TECHNICAL DATA TABLE

Not contractual information - given as an indication only and subject to change without notice.

TECHNICAL DATA	BALLOON LIGHT LED 4X100W	BALLOON LIGHT LED 6X100W
Power supply	100-240V 50-60Hz	100-240V 50-60Hz
Luminous flux	50000 Lm	60000 Lm
Module number	4	6
Power by bulb	100 W	100 W
Bulb type	LED	LED
Bulb socket	DOOSAN bulb socket	DOOSAN bulb socket
Restrike type	-	-
Restrike time	< 2 seconds	< 2 seconds
Power supplied by exterior ballast	No	No
Colour temperature	6000 °K	6000 °K
Average bulb life	> 50000 h	> 50000 h
Protection type	Fuse	Pressure switch Breaker Fuse
Anti-vibration system	No	Yes
Envelope diameter	90 cm	90 cm
Envelope shape	Tubular	Tubular
Weight	7 kg	8.3 kg
Max. ambient temperature	45 °C	45 °C
Power	410 W	610 W
Power generating unit	1 kVA	1 kVA
Bulb number	4	6

PARTS SECTION

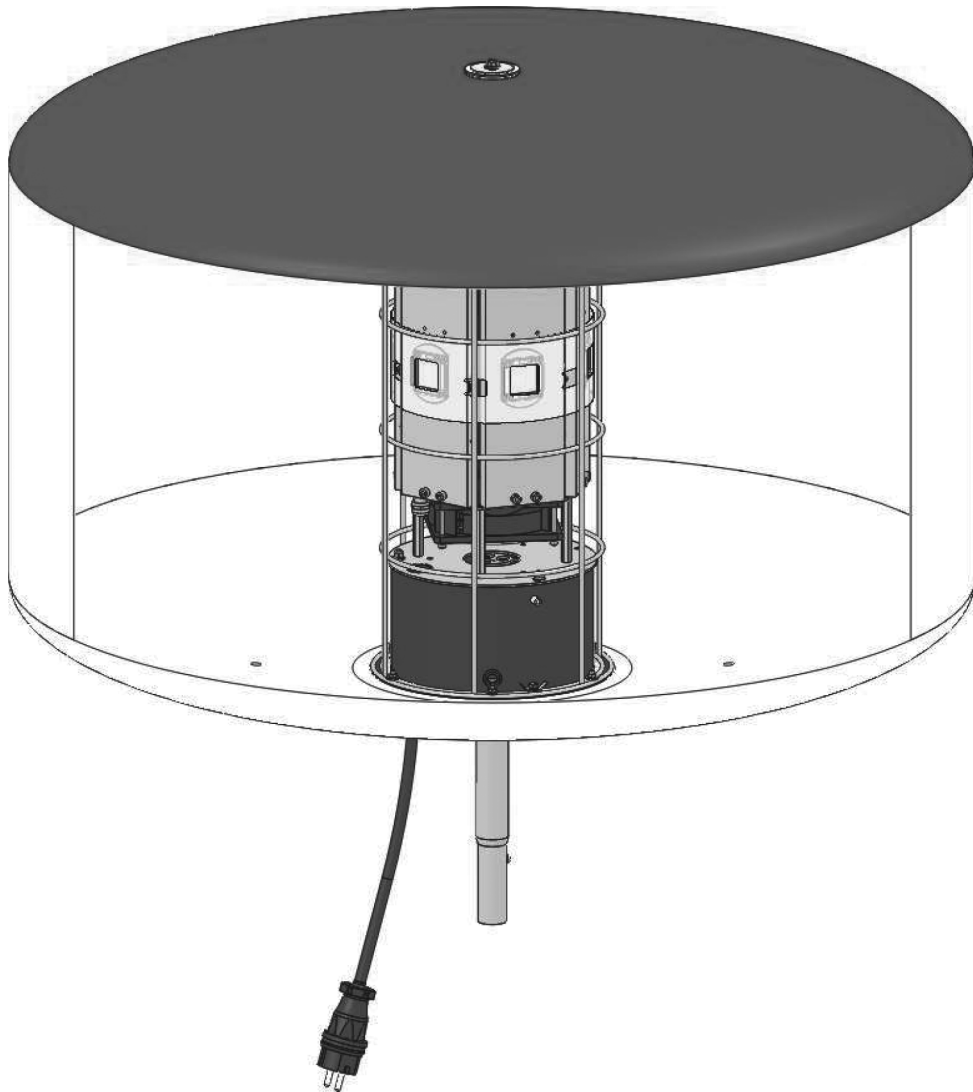

FRAME AND ENVELOPE

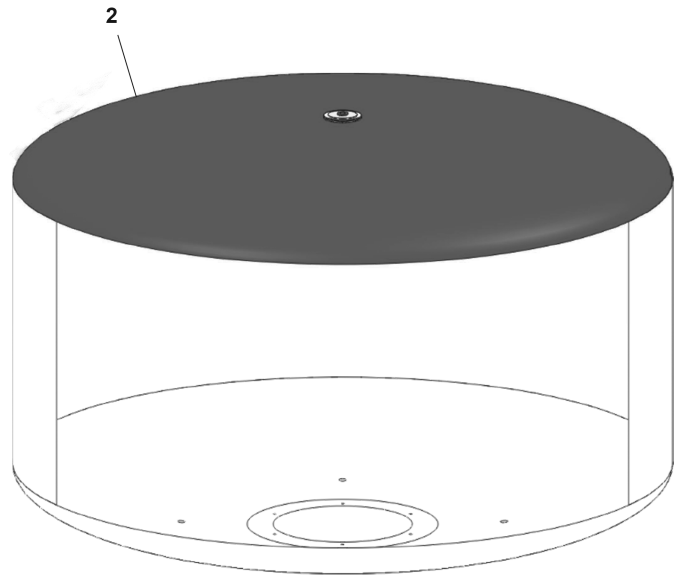
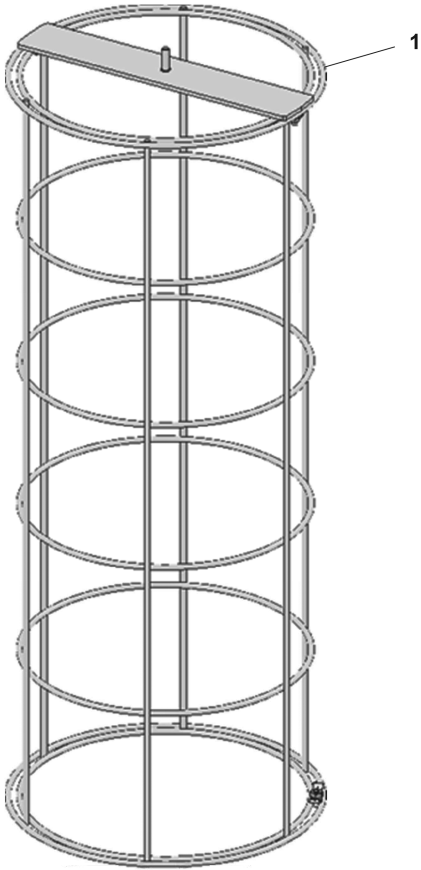

T3041_00
05/17

ITEM	PART NUMBER	DESCRIPTION	QTY.
1	46700839	Frame	1
2	46700821	Envelope	1

LEDs AND FAN - BL400

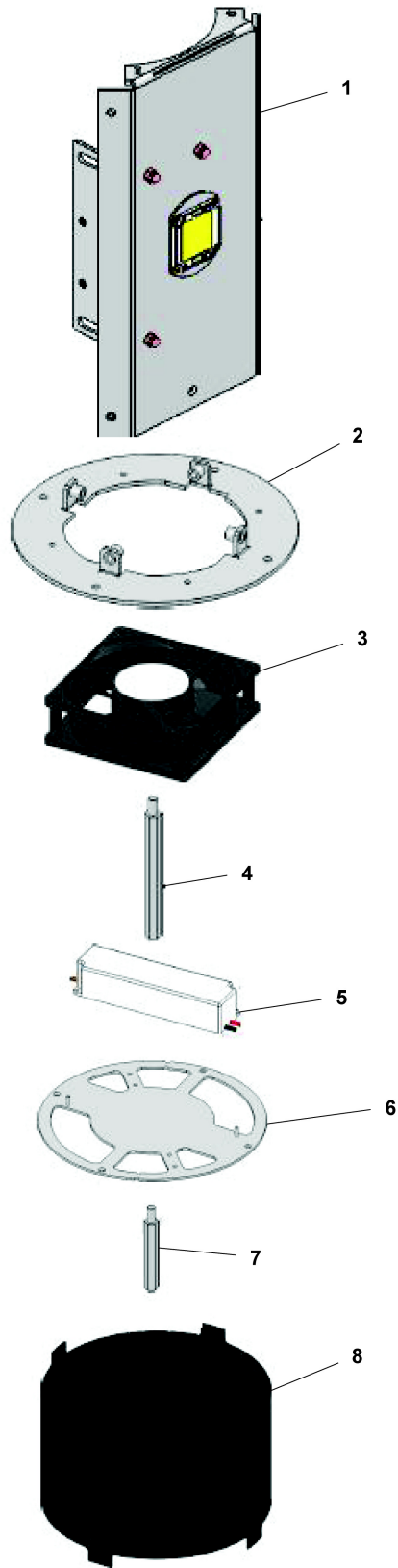

T3048_00
01/18

ITEM	PART NUMBER	DESCRIPTION	QTY.
1	46769985	LED Module	4
2	46769986	Bracket, upper	1
3	46769987	Fan	1
4	46769988	Spacer	4
5	46769989	Circuit board assembly	1
6	46769994	Bracket, lower	1
7	46700846	Spacer	4
8	46769991	Housing	1

LEDs AND FAN - BL600

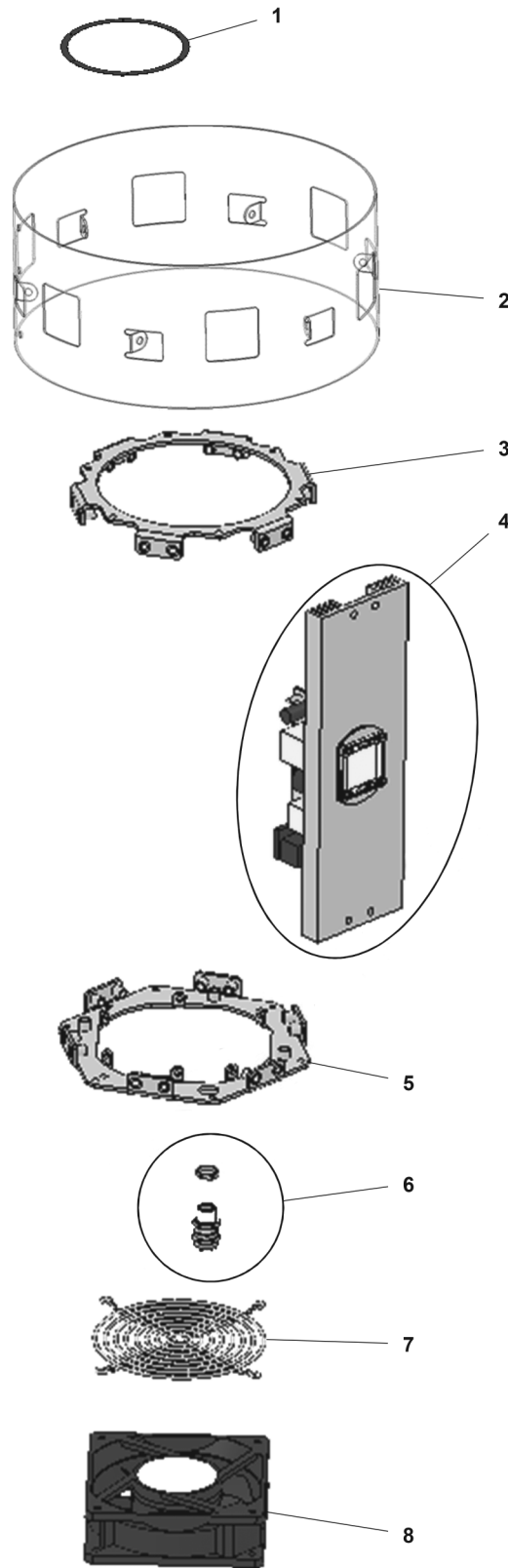

T3042_00
05/17

ITEM	PART NUMBER	DESCRIPTION	QTY.
1	46700836	Kit, strap harness	1
2	46700828	Cover	1
3	46700840	Bracket, upper	1
4	46700835	LED Module	6
5	46700837	Bracket, lower	1
6	46700832	Kit, PE and CE	1
7	46700856	Guard	1
8	46700857	Fan	1

HOUSING AND BASEPLATE ASSEMBLY - BL400

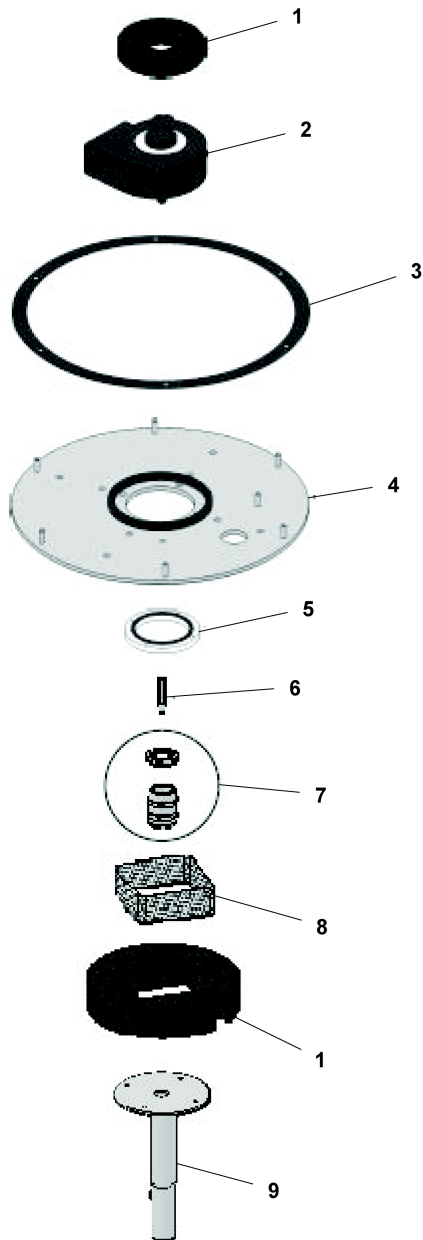

T3049_00
01/18

ITEM	PART NUMBER	DESCRIPTION	QTY.
1	46700862	Kit, foam (15 pieces)	1
2	46769993	Fan	1
3	46700858	Gasket	1
4	46769992	Plate, lower	1
5	46700829	Ring	1
6	46700838	Spacer	4
7	46769990	Kit, grip	1
8	46700842	Grid, airfilter	1
9	46700843	Base plate and foot	1

HOUSING AND BASEPLATE ASSEMBLY - BL600

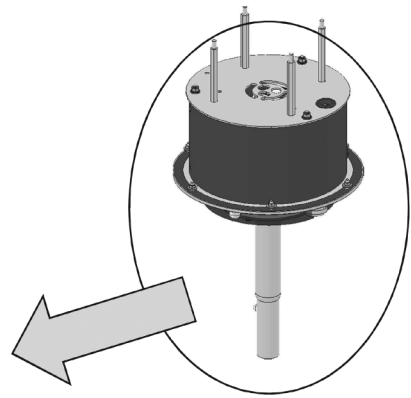
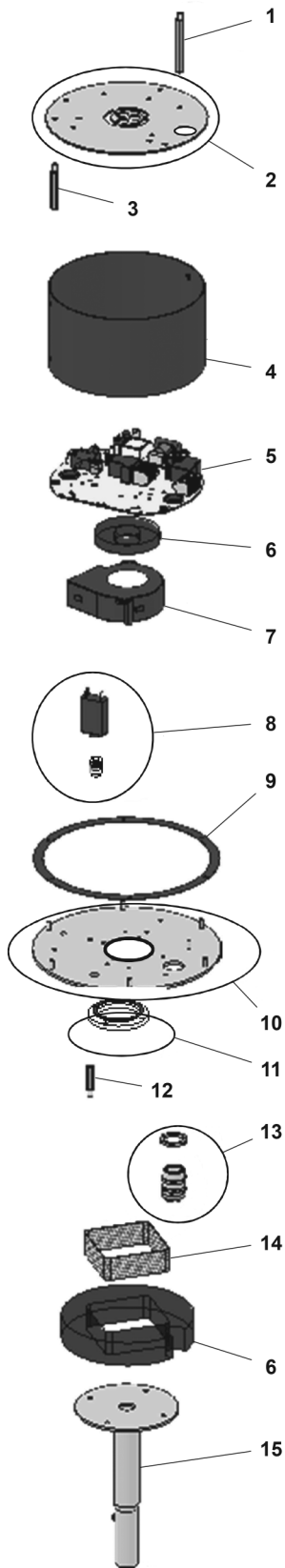

T3043_00
05/17

ITEM	PART NUMBER	DESCRIPTION	QTY.
1	46700838	Spacer	4
2	46700833	Plate, upper	1
3	46700846	Spacer	4
4	46700823	Housing	1
5	46700851	Circuit board assembly	1
6	46700862	Kit, foam (15 pieces)	1
7	46700855	Fan	1
8	46700831	Kit, cover and circuit breaker	1
9	46700858	Gasket	1
10	46700834	Plate, lower	1
11	46700829	Ring	1
12	46700838	Spacer	1
13	46700825	Kit, grip	1
14	46700842	Grid, air filter	1
15	46700843	Baseplate and foot	1

CIRCUIT BOARD ASSEMBLY - BL600

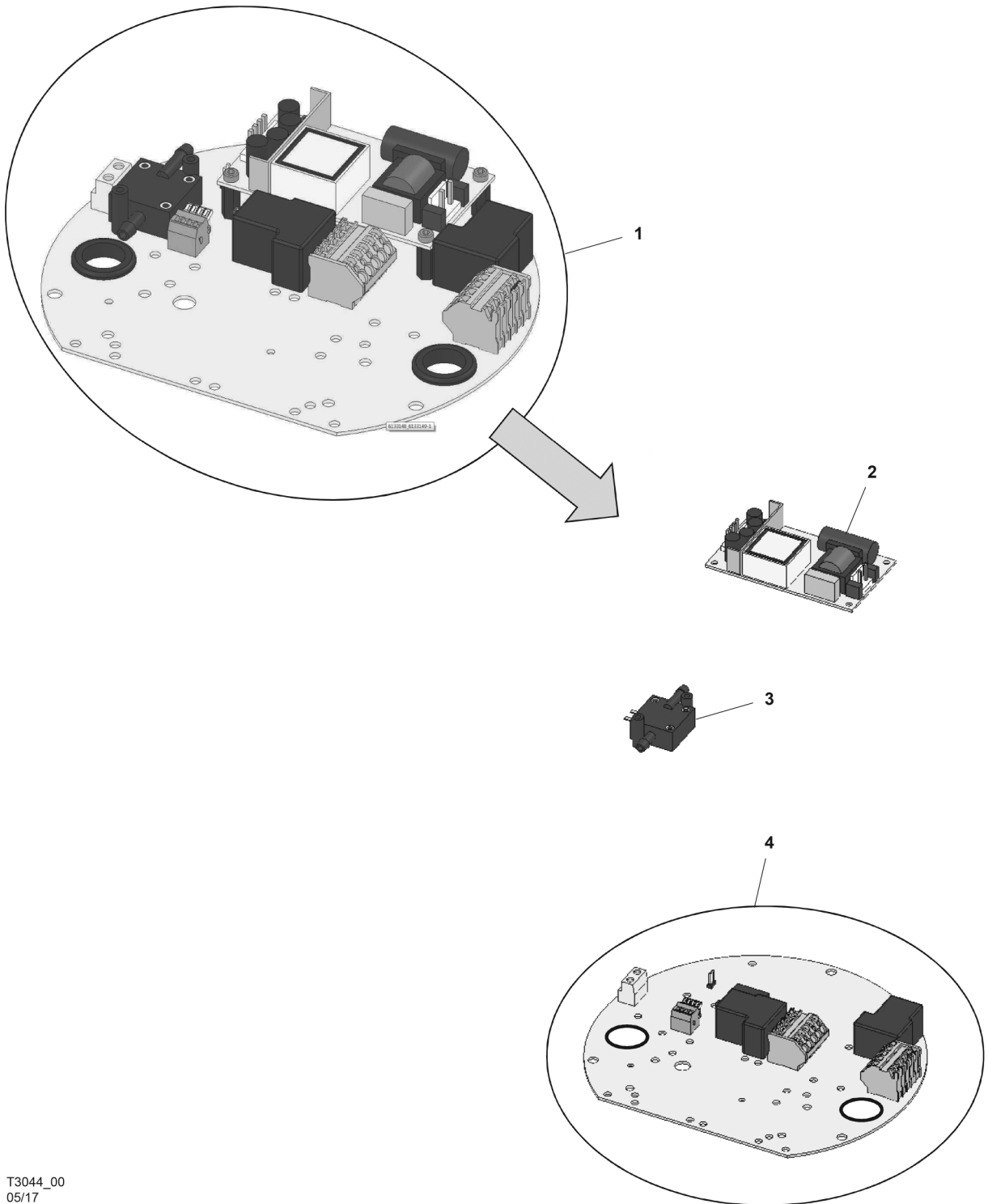

T3044_00
05/17

ITEM	PART NUMBER	DESCRIPTION	QTY.
1	46700851	Circuit board assembly (W/Ref. 2-4)	1
2	46700845	Transformer	1
3	46700844	Sensor, pressure	1
4	46700830	Motherboard	1

ELECTRICAL PLUGS - VARIANTS

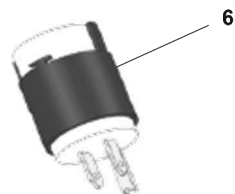
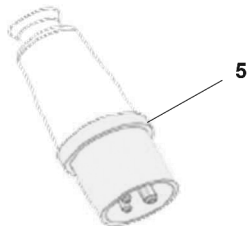
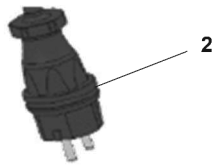
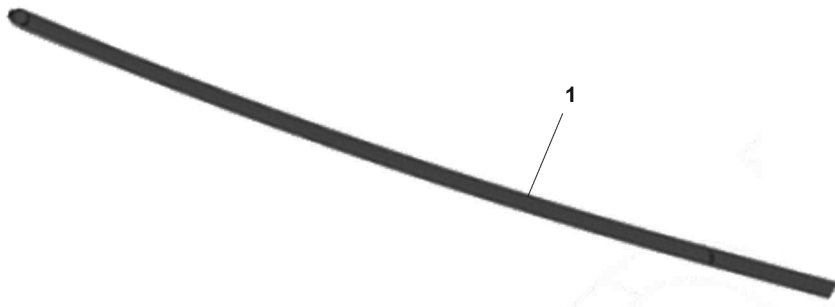

T3045_00
05/17

ITEM	PART NUMBER	DESCRIPTION	QTY.
1	46700847	Cable (9,2 m long)	1
2	46700849	Plug version FRD	1
3	46700850	Plug version CH	1
4	46700848	Plug version IEC	1
5	46700854	Plug version IEC UK	1
6	46700852	Plug version US	1

ACCESSORIES

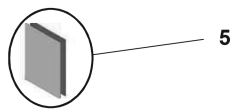
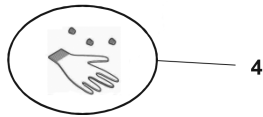
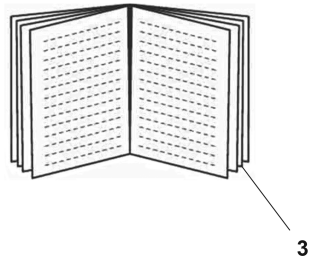
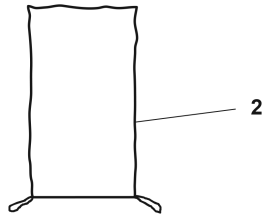
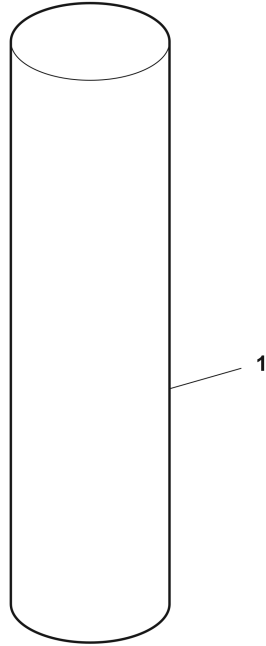

T3046_00
06/17

ITEM	PART NUMBER	DESCRIPTION	QTY.
1	46700859	Container	1
2	46700826	Pouch	1
3	46702181	Manual	1
4	46700824	Kit, inflatable	1
5	46700827	Kit, repair (2 sheets)	1

TELESCOPIC STAND (OPTIONAL)

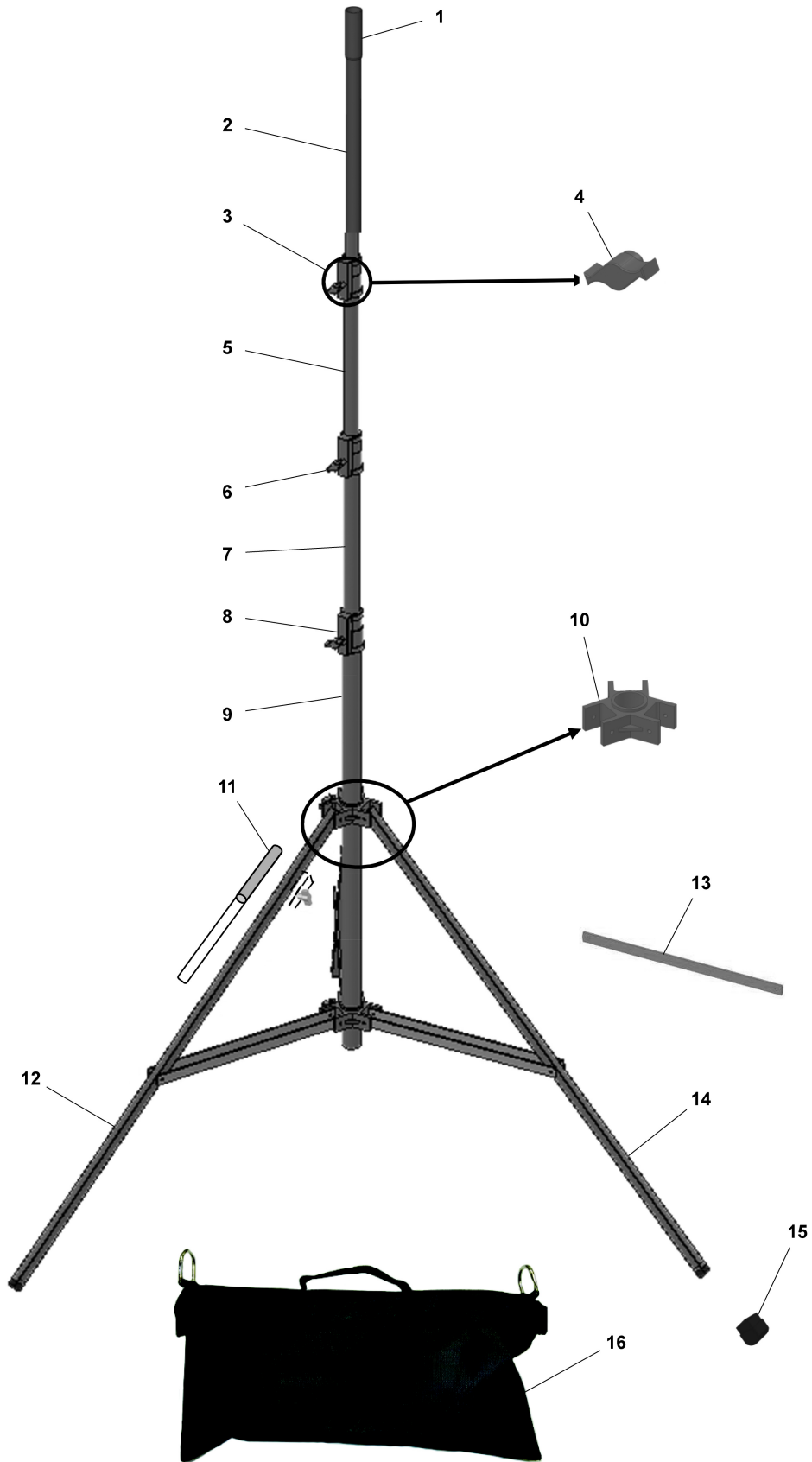

T3047_01
01/19

ITEM	PART NUMBER	DESCRIPTION	QTY.
1	46700822	Stand, telescopic (W/Ref. 2-15)	1
2	46700861	Riser	1
3	46700869	Junction, upper	1
4	46700866	Handle, screw	3
5	46700865	Tube, upper	1
6	46700871	Junction, middle	1
7	46700870	Tube, middle	1
8	46700864	Junction, lower	1
9	46700868	Tube, lower	1
10	46700867	"Spider"	2
11	46700873	Leg, telescopic, upper	3
12	46700874	Leg, telescopic, lower	3
13	46700863	Brace	3
14	46700872	Foot	3
15	46700875	Cap	3
16	46766325	Sandbag	3

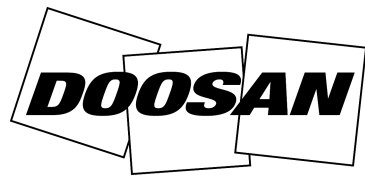

Portable Power